

ACTUATOR SERIES 90 3-POINT

ESBE actuator Series 90 for operating ESBE mixing valves DN 15–150. This series is provided with adjustable cam discs to obtain an operating range 30°–180° or even 270°, depending on version, which makes the series very flexible.



3-point

OPERATION

The ESBE series 90 actuator is a compact actuator for operating rotary mixing valves. The actuator is reversible and is provided with limit switches which are actuated by cam discs. By adjusting the cam discs an operating range from 30° to 180° can be obtained except for 1205 33 00 which has an operating range of 270°. The actuator is provided with a disconnection for manual operation and has an indication on the front showing valve position.

The 3-point signal control actuator is available for 24 V AC, 50/60 Hz, or 230V, 50 Hz with different running times as shown in the table.

OPTIONS

Separate auxiliary switch, see table next page marked **
_____ Art. No. 98100690



1 To operate the valve manually, push the button and use the lever. The electric current is automatically disconnected as long as the button is in the lower position.

2 Turn the valve to the desired position.



3 To return to automatic operation, bring the lever to the position where it locks, and the button returns to the upper position. The current supply is now connected.

SUITABLE MIXING VALVES

- Series VRG100*
- Series MG
- Series VRG200*
- Series G
- Series VRG300*
- Series F
- Series VRH100*
- Series BIV
- Series VRB100*
- Series T, TM
- Series H and HG

*Separate adaptor kit is required, see below

ADAPTOR KITS

Required adaptor kits for easily fitting onto an ESBE rotary mixing valve is available in two different styles. Adaptor kit designed for ESBE mixing valve series MG, G, F, BIV, H, HG is supplied with each actuator. Adaptor kits for ESBE mixing valve series VRG and VRB can be ordered separately.

Art. No.

16051300 (= supplied with actuator)

_____ ESBE valve series MG, G, F, BIV, T, TM, H, HG

16053400 (= supplied with Art. No. 12053300)

_____ ESBE valve series MG, G, F, BIV, T, TM, H, HG

16053300 _____ ESBE valve series VRG, VRB

Adaptor kits for other mixing valves and valves built-into boilers are available as follows:

Art. No.

16053500 _____ BRV

16053900 _____ Honeywell Centra ZR, DR, DRG, DRU
_____ (DN15 – DN50)

16051700 _____ Honeywell Centra Kompakt DRK/ZRK

16051900 _____ CTC, linear movement

16053600 _____ BRV, Meibes, Oventrop, Watts

16051300 _____ Sauter MH32...H42...

16052500 _____ Siemens VBG31, VBI31, VBF21, VCI31

16051400 _____ TA-VTR, TA-STM

16052600 _____ Schneider Electric/TAC-TRV

16051500 _____ Viessmann (DN20 – DN25)

16051800 _____ WITA

TECHNICAL DATA

Ambient temperature: _____ max. +55°C

_____ min. –15°C

Power supply: _____ 24 ± 10% V AC, 50 Hz

_____ 230 ± 10% V AC, 50 Hz

Power consumption: _____ Actuator 24 V AC, 2 VA

_____ Actuator 230 V AC, 5 VA

Enclosure rating: _____ IP 54

Protection class: _____ II

Torque: _____ See table

Rating auxiliary switch: _____ 6(3) A 250 V AC

Weight: _____ 0.8 kg

CE LVD 2014/35/EU
EMC 2014/30/EU
RoHS 2011/65/EU

ACTUATOR SERIES 90 3-POINT

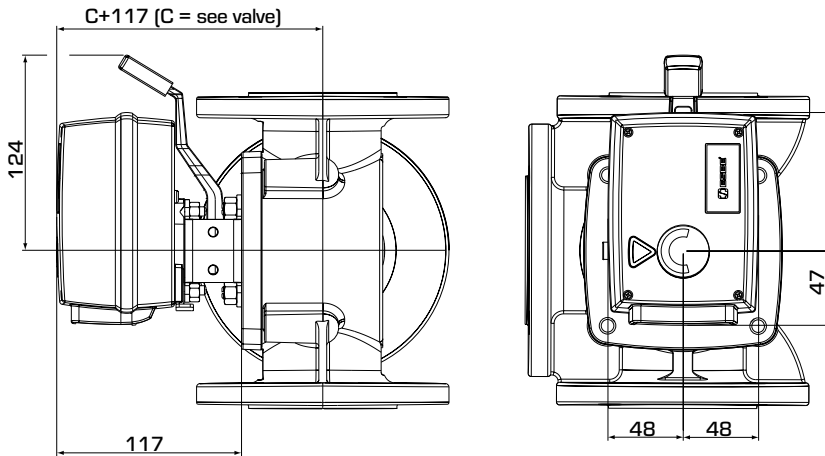

Installation dimensions for Actuator Series 90 with ESBE series MG, G, F, T/TM, H/HG and BIV mixing valves

SERIES 90, 3-POINT 24 V AC

Art. No.	Reference	Voltage [V AC]	Running time 90° [s]	Torque [Nm]	Control signal*	Remark
12050200	91	24	15	5	3-point SPDT	Separate auxiliary switch as option**
12050400	91M					With premounted auxiliary switch
12050600	92	24	60	15	3-point SPDT	Separate auxiliary switch as option**
12051100	92M					With premounted auxiliary switch
12050700	92-2	24	120	15	3-point SPDT	Separate auxiliary switch as option**
12050900	92-2M					With premounted auxiliary switch
12051300	93	24	240	15	3-point SPDT	Separate auxiliary switch as option**
12051500	93M					With premounted auxiliary switch

SERIES 90, 3-POINT 230 V AC

Art. No.	Reference	Voltage [V AC]	Running time 90° [s]	Torque [Nm]	Control signal*	Remark
12051700	94	230	15	5	3-point SPDT	Separate auxiliary switch as option**
12051800	94M					With premounted auxiliary switch
12051900	95	230	60	15	3-point SPDT	Separate auxiliary switch as option**
12052200	95M					With premounted auxiliary switch
12052000	95-2	230	120	15	3-point SPDT	Separate auxiliary switch as option**
12052100	95-2M					With premounted auxiliary switch
12053300	95-270M	230	50***	5	3-point SPDT	With premounted auxiliary switch Operating range 270°
12052300	96	230	240	15	3-point SPDT	Separate auxiliary switch as option**
12052400	96M					With premounted auxiliary switch

* 3-point SPDT = Single Pole Double Throw *** Running time 270° - 150s (preset)

WIRING

The actuator should be preceded by a multi-pole contact breaker in the fixed installation.

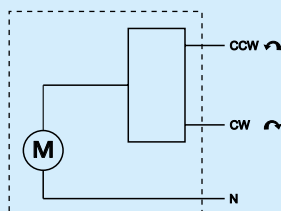

Actuator, Art. No.
12050200, 12050600, 12050700,
12051300, 12051700, 12051900,
12052000, 12052300

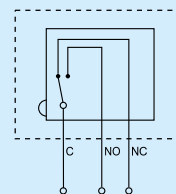

Auxiliary switch

Actuator with premounted auxiliary switch, Art. No.
1205 (04) 00, (09), (11), (15), (18), (21), (22), (24), (33)
These actuators are supplied with one auxiliary switch. To set the switch position, remove the actuator cover and turn the cam sleeve to the desired position.